

DynaTrac[®]

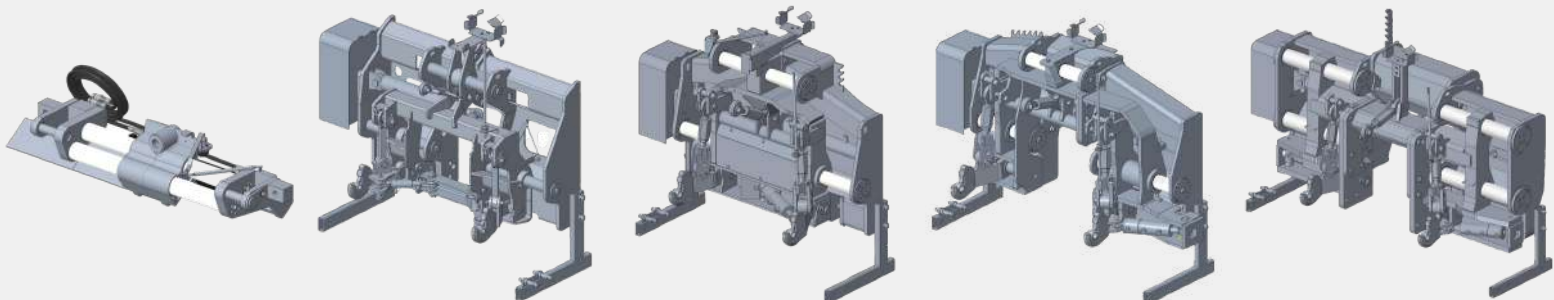

*A complete range of precision
guidance interfaces!*



www.laforgegroup.com



WHY DYNATRAC ?

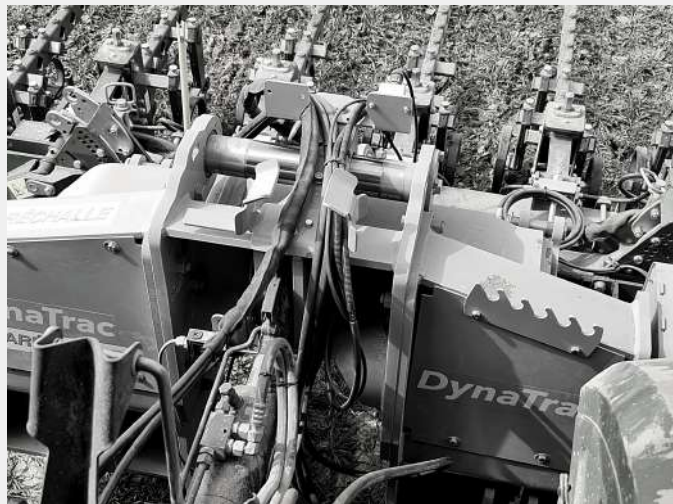

↳ Laforge offers an interface wich ensures repeatable and accurate implement positioning, regardless of the operation performed

↳ Farmers benefit from the gains generated by precision agriculture with implements already available at the farm

Benefits of the interface

- Higher yields
- Improved productivity
- Operational savings
- Reduced operator fatigue
- Reduced inputs by eliminating overlap of fertilizer, seed, chemical and tillage operations

DynaTrac operating principle

Ensures perfect tracking of the tractor's A-B line, while using the implement's natural line of traction.

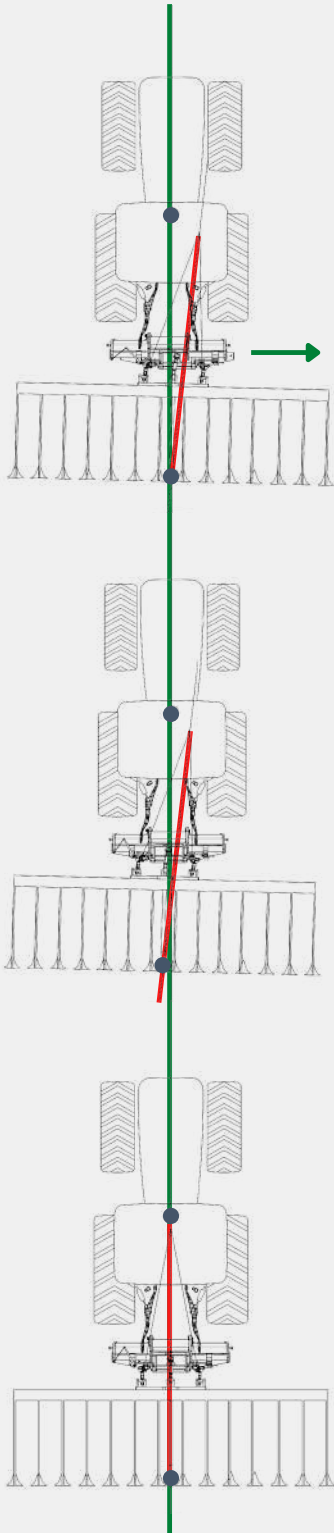

STEP 3

The DynaTrac moves laterally to center the implement antenna on the A-B line while maintaining the natural line of pull without lateral constraint

STEP 2

The implement drifts away from the line A-B
The natural line of traction forms an angle with the direction of travel

STEP 1

Straight pull: Implement follows same A-B line as the tractor

RECEIVER ●

A-B LINE —

LINE OF DRAFT —

DynaTrac® shifting →

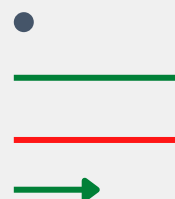

“ With DynaTrac, my implement guidance doesn't interfere with the tractor guidance. ”



The *DynaTrac CLASSIC* is dedicated to guiding trailed or semi-mounted implements.

- Guarantees precision during strip-till, planting, etc.
- Facilitates spraying and harvesting by using accurate and steady A - B lines.
- Increases efficiency and comfort for the operator: precision allows to go faster, longer!

It corrects the implement position on flat fields and slopes up to 12%.

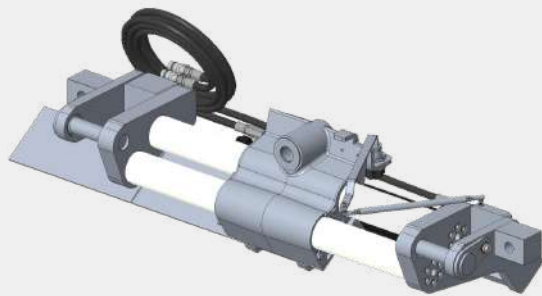

Travel range	50 cm / 20"
PTO drive line compatibility	No
Maximum power tractor	400 HP
Hitch tractor / implement side	Cat. 3W / 4N



CLASSIC

Replaces the original 2-point hitch for planters:

- John Deere NT
- White / Case IH 1250 and 2150



Receives a broad range of adaptors to:

Ensure compatibility with a wide variety of trailed implements (strip-till, planter, etc.)



“Great accuracy! Eliminates guess rows! I don't have any issues running a 12 row corn head and a 16 row planter because the rows are uniformly spaced pass to pass.”

DynaTrac CLASSIC user



A complete range of

COMPACT

The *DynaTrac COMPACT* is the optimized version to carry implements up to 1500 kg.

It is suitable for all types of work and especially for row crop cultivation and vegetable crops.

It corrects implement position on flat fields and slopes up to 15% (mounted implements)!

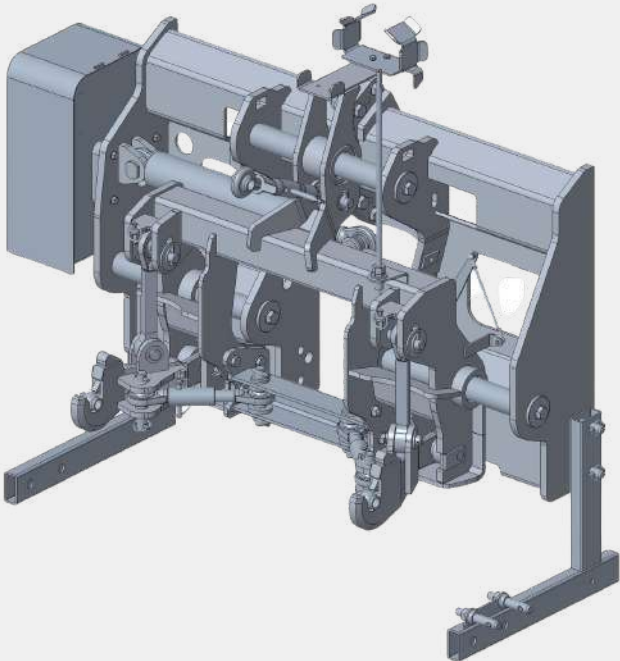

Travel range	30 cm / 12"
PTO drive line compatibility	Yes
Maximum implement weight	1 500 kg
Hltch tractor / implement side	Cat. 2



“Worth it! This is truly a solution that pays you back all year long because of its accuracy in keeping each implement where it should be.”

DynaTrac COMPACT user

universal guidance interfaces,

PREMIUM

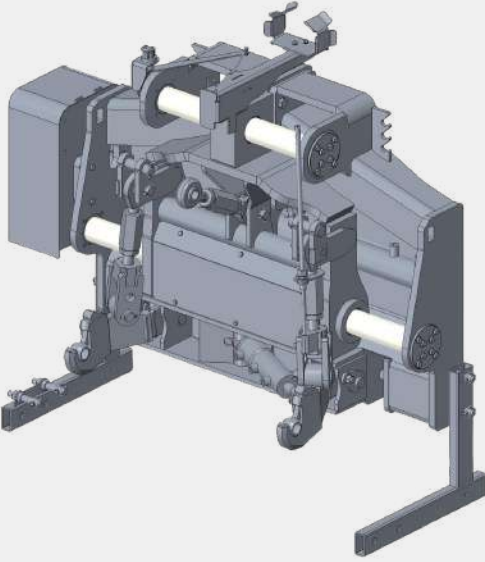

The *DynaTrac PREMIUM* is designed to carry implements up to 4000 kg.

With a large shifting range, this model is ideal when PTO compatibility is not required.

It can carry out many operations and more specifically row crop cultivation.

It corrects mounted implement position on flat fields and slopes up to 25% (trailed implement: 12%).

Travel range	50 cm / 20"
PTO drive line compatibility	No
Maximum implement weight	4 000 kg
Tractor hitch / implement side	Cat. 3N



“Top productivity! I can run higher ground speeds and cover more acres in a day with my cultivator. I trust my guidance system to prevent the cultivator from damaging my crops.”

DynaTrac PREMIUM user

fitting all types of

PREMIUM+

The *DynaTrac PREMIUM+* is designed to carry implements up to 5000 kg.

The PTO compatibility makes this model fully versatile. It can steer any implement (strip-till, bedder, planter, RC cultivator, etc.).

It corrects the implement position on flat fields and slopes up to 15% (mounted implements)!

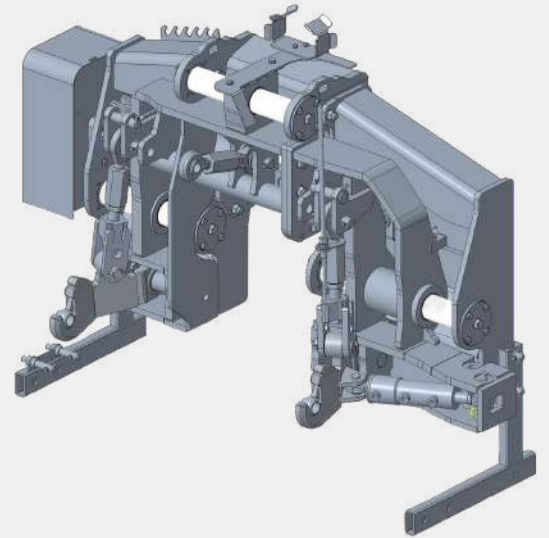

Travel range	30 cm / 12"
PTO drive line compatibility	Yes
Maximum implement weight	5 000 kg
Hitch <ul style="list-style-type: none">• Tractor side• Implement side	Cat. 3W Cat. 3N/3W (adjustable)



“ Very efficient! When there are several passes in a field, the implement is always where it should be. ”

DynaTrac PREMIUM+ user

tractors and implements!

ULTIMA

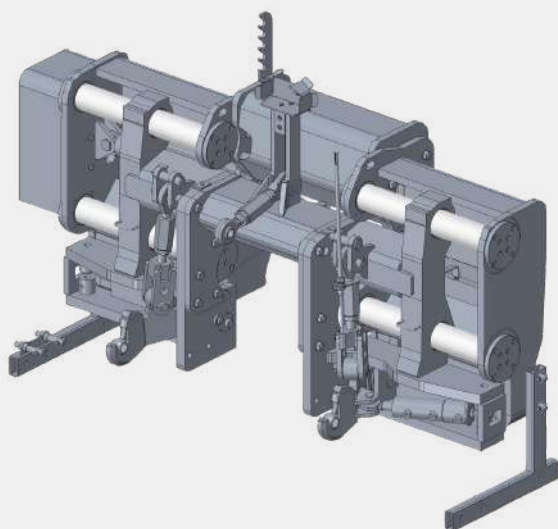

The *DynaTrac ULTIMA* is the most suitable model for high-power tractors.

It can work with mounted implements up to 7500 kg (25T for semi-mounted or trailed implements) or with large width implements.

It corrects mounted implements position on flat fields and slopes up to 25% (trailed implements: 12%).



Travel range	50 cm / 30"
PTO drive line compatibility	Yes
Maximum implement weight	7 500 kg
Hitch tractor / implement side	Cat. 3W or 4N



“ Better harvest! Increased marketable yields : less damage during crop growth and harvest. ”

DynaTrac ULTIMA user

How to steer a DynaTrac?

GPS Guidance

Can be used in all conditions

- **Efficient:** guaranteed precision work at every stage of the crop
- **Cost-effective:** only one guidance function needed!
- **Optimized row crop cultivation:** overcome the limits of camera guidance -> the crop does not need to be visible



Camera Guidance

Can be used when crop is visible

- **Universal:** compatible with any brand of cultivator
- **Cost-effective:** one guidance function for several cultivators
- **Efficient:** no interference between tractor and cultivator movements
- **Scalable:** switch to GPS guidance once the benefits of camera guidance are reached



Sonic Guidance

Can be used when a shape is available

- **Universal:** compatible with all implement types and uses ultrasonic sensors to control the implements position.
- **Cost-effective:** one guidance solution for multiple operations in a growing season. Integrates through the tractor ISO VT
- **Effective:** works in conditions with as little as 3 inches / 8 centimeters of differential



What makes DynaTrac 3-point universal and efficient?

DynaTrac® 3-point has an exclusive design that retains all the functionalities of a rear tractor hitch. Allowing it to easily, precisely and repeatedly locate the implement according to the guidance system.

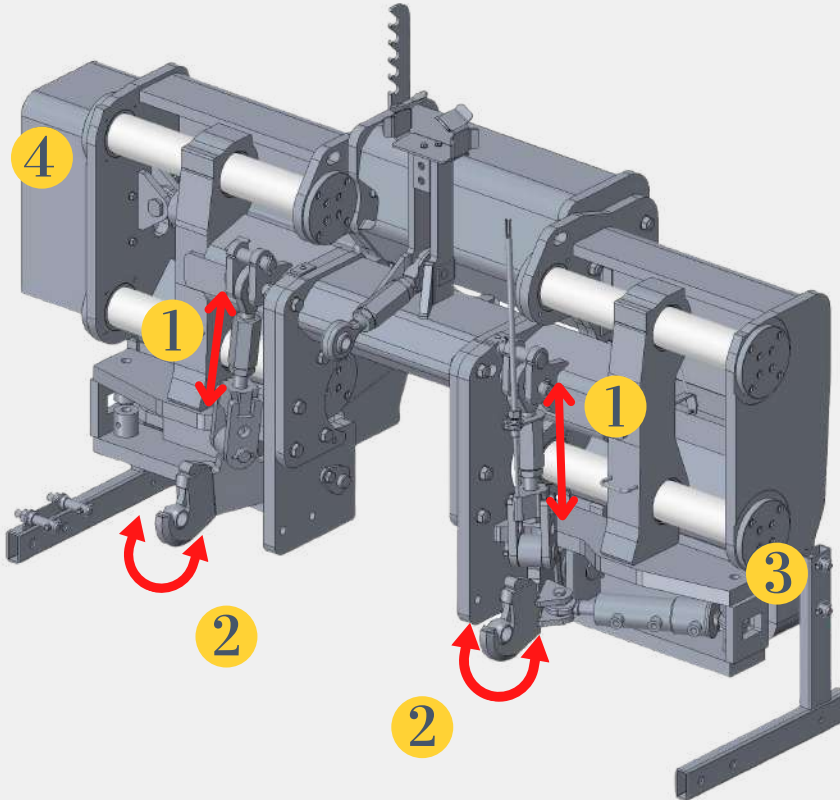

1 Free vertical float



- DynaTrac's floating function allows the implement to follow the shape of the field.
- The interface weight remains on the tractor: improves traction and reduces slippage.
- **The** implement does not carry the interface's weight: makes steering easier.

3 Sway control cylinders



- Free sway at work with 3-point implements.
- Lock during transport and with 2-point or trailed implements.
- Controlled with automatic tractor sequences
- For Compact : locked by pin

2

Pivot-mounted arms (free lateral sway)

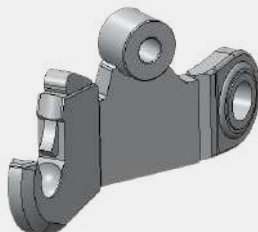

- Disconnects the implement motion from the tractor (patented feature) :
- Avoid side load on implement → no damage to the implement nor implement getting locked in the ground.
- Perfect implement trailing. Tractor positioning corrections do not impact trailing and vice versa.

4

Feed back sensor

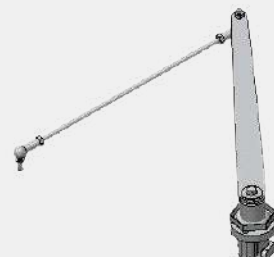

Informs the control unit (GPS Guidance or Camera) of the DynaTrac position.



Europe: LAFORGE, France
Phone : +33 323 798 585

North America: LAFORGE Systems LLC, Iowa, USA
Phone : 1-855-408-3332

www.laforgegroup.com